

全自动双压头打包机

Full Automatic Two Ram Balers

机器应用

适用于废纸、塑料、布料等固体废料的回收打包,方便储运,减少人工成本。

Usage

Specialized in recycling and compressing the waste paper, plastic film, fabric etc, convenient for storage, saving labor cost.

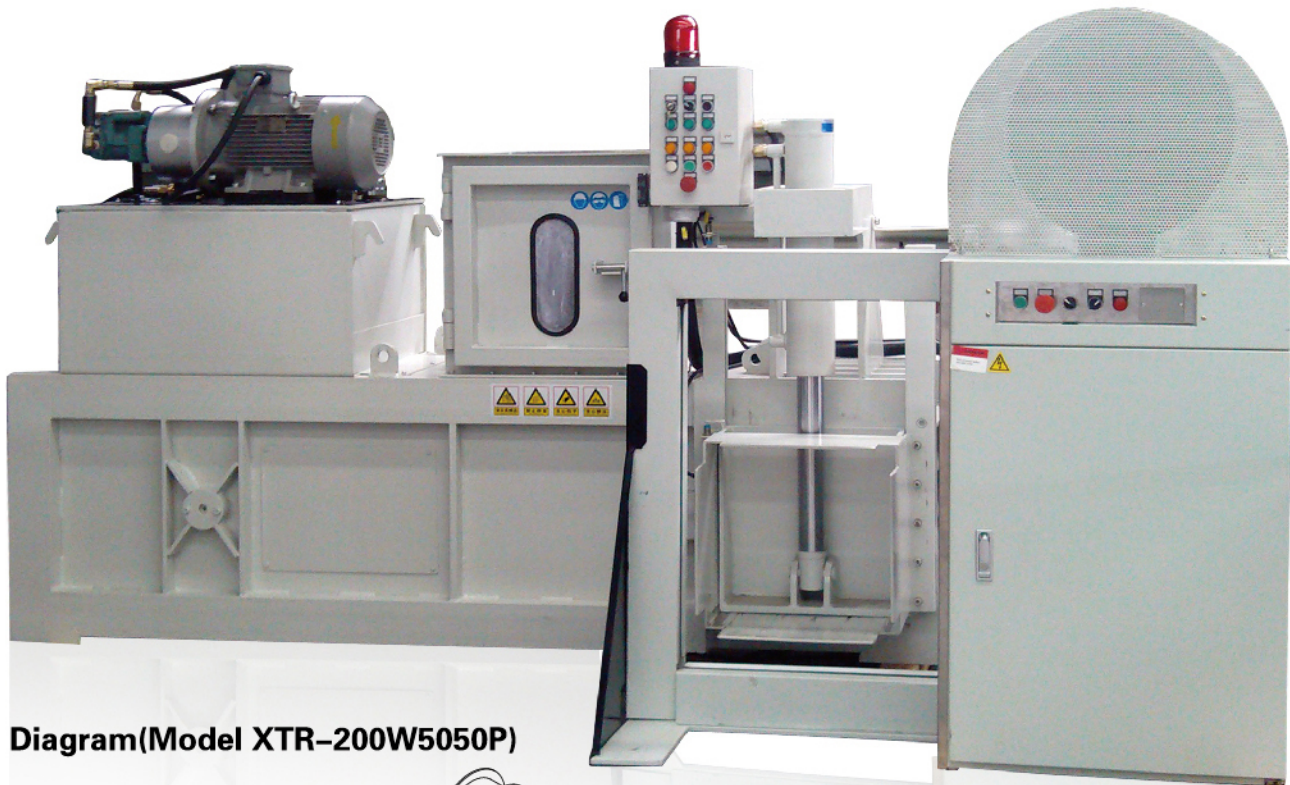

Diagram(Model XTR-200W5050P)

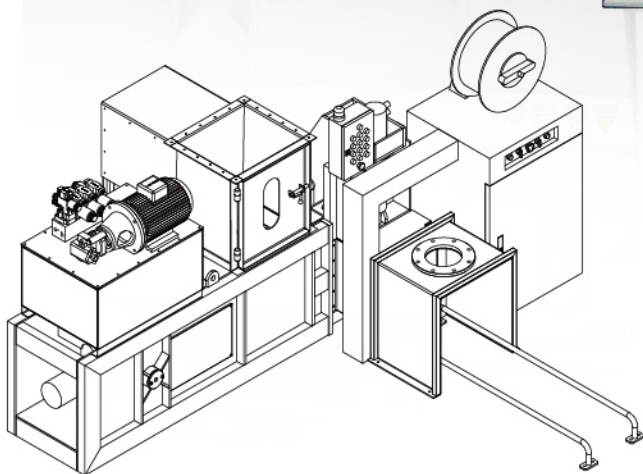

Bale Size(Model XTR-200W5050P)

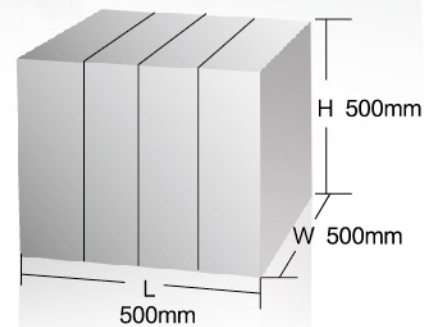

参数 Specifications

型号	XTR-200W5050P	XTR-400W7575P
压力 Pressure	20tons	40tons
电机功率 Motor Power	7.5kw	15kw
油箱容积 Oil Tank Volume	160L	540L
加料口尺寸(L*W) Feed Opening Size(L*W)	500*480mm	1100*730mm
包块尺寸(L*W*H) Bale Size(L*W*H)	500*500*500mm	750*750*750mm
包块重量 Bale Weight	30~70kgs	70~150kgs
捆包道数 Number Of Belting	3lines	3~5lines
机器外形尺寸(L*W*H) Machine Overall Dimension(L*W*H)	3212*2600*1630mm	4650*3010*2430mm
机器重量 Machine Weight	2.5tons	4.5tons

机器特点

- 压缩、打包自动完成，使用PP带捆扎，降低辅材费用
- 双压头设计，占地面积小，机构紧凑
- 采用吸风系统送料或者输送机送料
- PLC控制，捆扎道数多重选择
- 包块可直接进行完全焚烧，不留杂质



Features

- Automatically compressing and baling, using PP strap to reduce baling material cost
- With two rams design, compact machine structure occupying small space
- Cyclone system or conveyor could both be the optional for feeding
- With PLC control, number of belting is optional
- The bales could be directly burned out